

STEELFORCE SLS 670 EN527

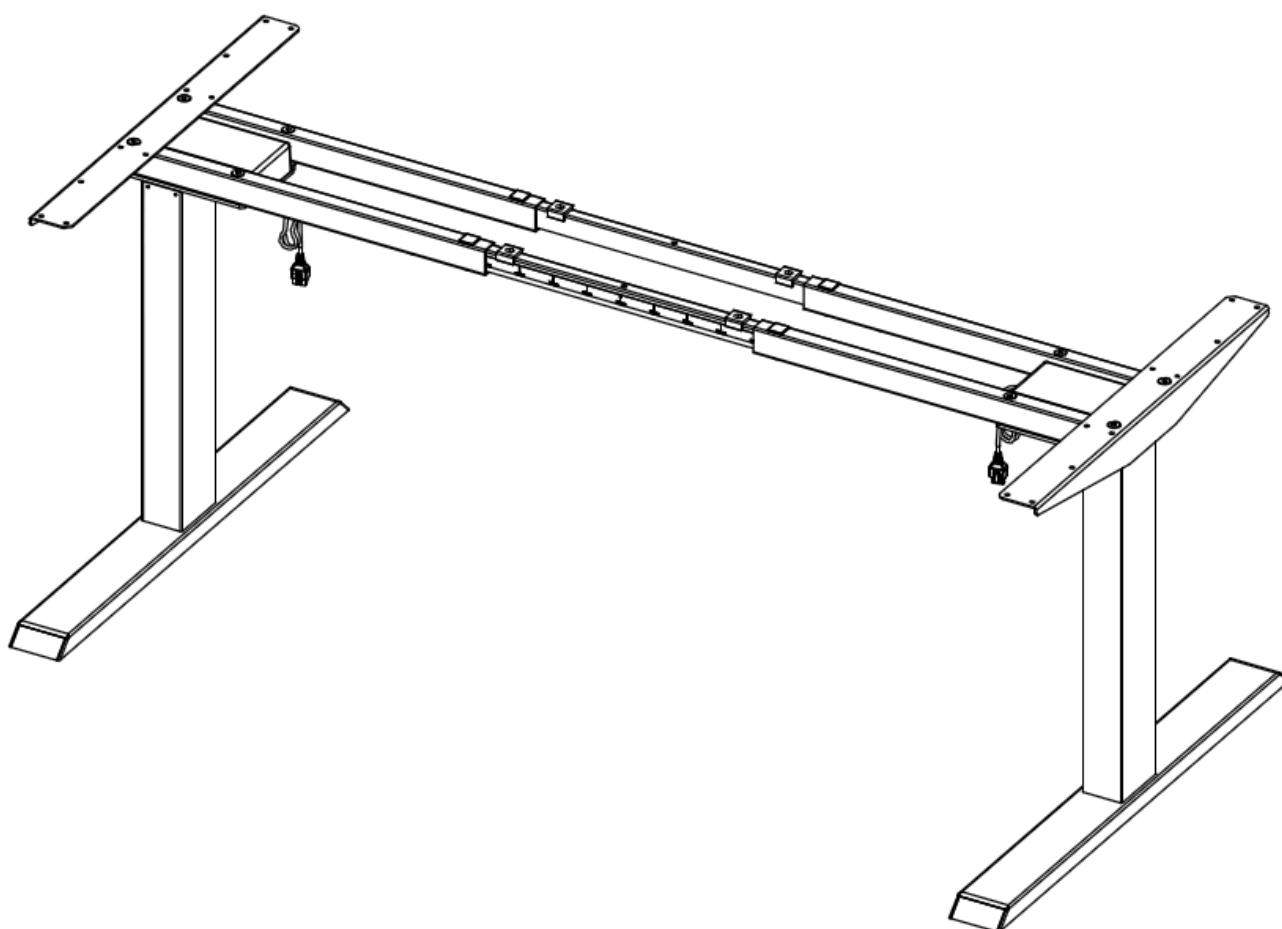

Assembly Manual

Read this manual thoroughly and store in a safe place.

Content

1	GENERAL	3
1.1	Local value of the assembly/operating manual	3
1.2	Intended use	3
1.3	Improper use	3
1.4	Content box	4
2	SAFETY INFORMATION	5
2.1	Symbols/warnings	5
2.2	Symbols used on the workstation frame	5
2.3	Organizational measures	5
2.4	Informal safety measures	5
2.5	Note for those assembling the workstation	5
2.6	Transport and assembly	5
2.7	Use of the workstation frame	5
2.8	Specific dangers	6
2.9	In an emergency	6
2.10	Maintenance and upkeep	6
2.11	Cleaning	6
2.12	Persistent risks	6
3	ASSEMBLY	7
3.1	Checking the items supplied.....	7
3.2	Packaging.....	7
3.3	Tightening torques for screws used	7
3.4	Assembly of the workstation	7
3.4.1	Pre-assembly of the Crossbars	7
3.4.2	Mounting the Feet.....	8
3.4.3	Mounting the Crossbar.....	9
3.4.4	Mounting the Top Support.....	10
3.4.5	Adjustment of the Frame Width	10
3.4.6	Mounting the Spacer	11
3.4.7	Connecting the Electrical Components	12
3.4.8	Mounting the table top	12
3.4.9	Mounting the power supply underneath the table top	12
3.4.10	Mounting wire clip.....	13
3.4.11	Frame Test without Tabletop	14
3.4.12	Clearance around the wall or moving parts 25mm of the table top.....	15
4.	CORRECT POSITION OF SEATS	16
5	TECHNICAL SPECIFICATIONS	17-18
6	OPERATION AND INDICATORS	19
6.1	Indicators	19
7	TROUBLESHOOTING	20
8	CUSTOMER SERVICE	21
9	MANUFACTURER	21
10	RECYCLING	21
10.1	Taking the workstation out of active duty	21
10.2	Taking the workstation apart	21
10.3	Recycling.....	21

1 General

1.1 Local value of the assembly/operating manual

The guiding principle for safe use and trouble-free operation of this workstation frame is knowledge of basic safety information and regulations. This assembly/operating manual contains the most important information needed for assembling and operating the workstation frame safely. This assembly/operating manual, in particular the safety information contained herein, must be observed by any person building the frame and working on the finished surface. More importantly, the rules and regulations applying to accident prevention in the locality in which the workstation frame is to be used must be observed at all times.

1.2 Intended use

The workstation frame must be used only as a height-adjustable workstation for sitting/standing use in offices or other enclosed areas. The frame must be used for this purpose only. The workstation frame may be set up and operated solely in office environments. Do not use the workstation frame in the home. Please observe the provisions of Section 2, Safety Information. Children may be unaware of the dangers presented by the workstation frame if unsupervised. Any other use than the above shall be deemed improper. The manufacturer can in no way be held liable for damage arising from improper use.

Intended use shall also include:

- Observation of all information from the assembly/operating manual and
- Prohibition of any sort of addition to/conversion of the workstation.

1.3 Improper use

Never use the workstation frame to lift people or loads.

Do not exceed the maximum load of the workstation frame.

Do not use the workstation frame in the home; alternatively, use it only in offices.

WARNING: Any changes or modifications not expressly approved by the manufacturer could void the user's authority to operate the equipment.

1.4 Content Box



Assembly requires 2 people !

Items

1 2x

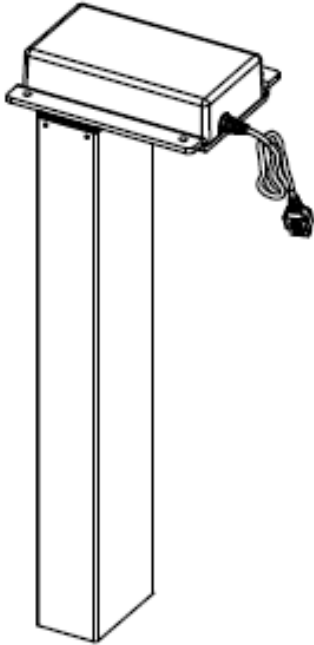

2 2x

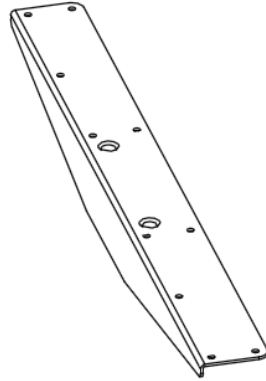

3 2x

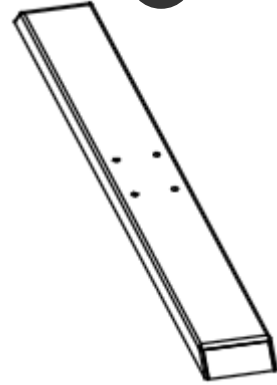

4 2x

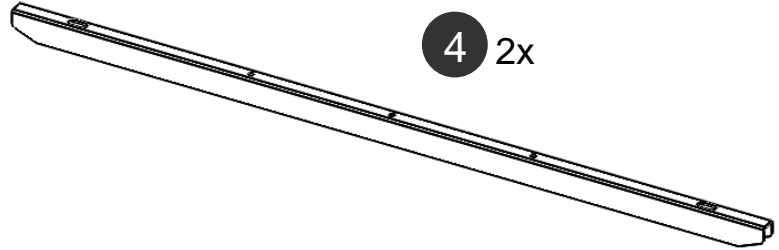

5 4x

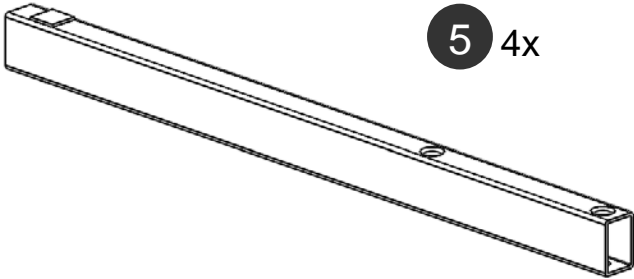

6 1x

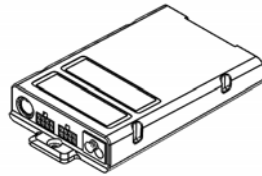

7 1x

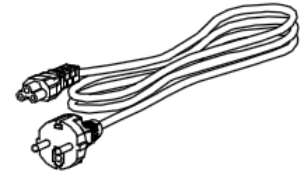

8 1x

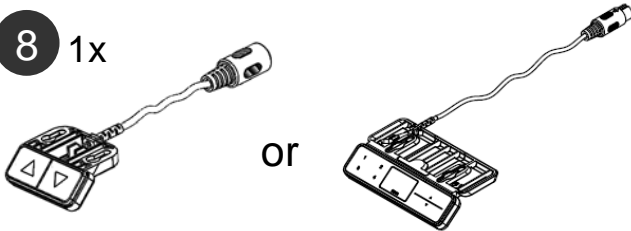

or

9 4x

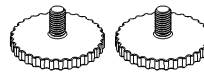

10 6x

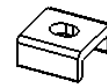

11 4x



Mounting Hardware Kit

A 8x

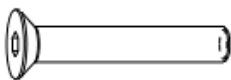

M8x50

B 8x



M6x16

C 8x

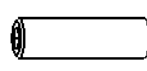

M10x35

D 28x



4.5x20

Tools



2 Safety Information

2.1 Symbols/warnings

The assembly/operating manual uses the following terms and signs to indicate dangers:



This symbol indicates an immediate threatening situation for any person's life or health. Failure to adhere to such information may have serious consequences for health, or could even result in life-threatening injury or death.



This symbol indicates important information. Failure to adhere to such information could lead to damage to the workstation.

2.2 Symbols used on the workstation frame



Do not place objects or parts of the body under the workstation frame or between the cross members. This could cause serious injury.



Do not exceed the maximum permitted load on the workstation frame. Overloading could lead to breakage and serious injury as a consequence.

2.3 Organizational measures

- The workstation frame can best be assembled by two people. Turning the frame, once the work surface has been fitted, is a task in particular which requires two people!

2.4 Informal safety measures

- Keep the assembly/operating manual in the place where the workstation frame is used at all times.
- Make sure that all safety information on the table (see Section 2.2, Symbols used on the workstation frame) is legible, replacing the same if necessary.

2.5 Note for those assembling the workstation

- The workstation must be assembled/worked on by persons over the age of 16.
- The persons referred to above must have read and understood the assembly/operating manual.

2.6 Transport and assembly

- The workstation frame must be moved by two persons only, and in such cases must be retracted.
- Do not drag or pull the workstation frame over the floor.
- Assemble the workstation frame with the supplied tools only. They are the only tools which ensure that the screws can be tightened to the correct torque.

2.7 Use of the workstation frame

- Do not allow children to use the workstation frame unsupervised. Children may be unaware of the dangers presented by the workstation frame. They would be in serious danger of injuring themselves, possibly even with fatal consequences. Further adjustment must then be impossible as a safeguard against use by children.
- The workstation frame must only be used in appropriate areas.
- Do not use the workstation frame on an uneven surface. In such conditions it will not be steady.
- Never exceed the maximum load on the workstation frame.

2.8 Specific dangers

- When adjusting the height of the frame there is danger of injury. Make sure that there is no-one else in the immediate surroundings of the frame.
- When assembling the workstation frame, make sure there is ample space to avoid collisions (i.e. inclination of roof, fixed objects, filing cabinets, waste-paper bins etc.) in all imaginable directions.
- Make sure there is ample space to avoid collisions if there are objects on the work surface such as computers or computer peripherals.
- Make sure there is clearance of at least 25 mm from all other furniture, all around the workstation frame.

2.9 In an emergency

- Stop using the workstation frame at once if you notice anything unusual (strange sounds etc.).
- Have the workstation frame repaired by specialists. Refrain from using the workstation frame until it has been successfully repaired.

2.10 Maintenance and upkeep

- The workstation frame and its components are low-maintenance items and need no special regular maintenance.
- Do not perform any repairs on the work surface or other components yourself.
- Do not alter the construction of the work surface or its frame.
- Any faulty components removed must be replaced with new, original components from the manufacturer. Use only original replacement parts made by the manufacturer. Have any such work carried out by a specialist, making reference to this Assembly/operating manual.

2.11 Cleaning

- Dust the workstation frame once a week with a dry cloth.
- Clean the workstation frame with a damp cloth and a weak solution of cleaner once a fortnight.

2.12 Persistent risks

This workstation frame has been built to the state of the art and to recognized safety regulations. Nonetheless, its use may constitute a risk to the health and safety of users or third parties, damage to the workstation frame or to other items. The workstation frame must be used only:

- for the purpose for which it was intended.
- if it is completely safe so to do.

3 Assembly



Before attempting assembly, read the safety information in Section 2.

3.1 Checking the items supplied

- Carefully open the cardboard packaging.
- In doing so, do not use any long knife blades. They may damage the components inside.
- Check the parts supplied against the list in Section 1.4 Content box.
- Do not attempt to assemble the workstation frame if there is any damage or if there are any incorrect components.

3.2 Packaging

- Remove the packaging. Treat as household waste/paper.
- Observe national legislation.

3.3 Tightening torques for screws used

- Assemble the workstation frame with the tools supplied only.

3.4 Assembly of the workstation

3.4.1 Pre-assembly of the Crossbars

Assemble the following components:

Indicative :			
Frame set-up	Width / size table top	Depth / size table top	Table Top Thickness
110 cm	120 cm	80 cm	2.5 cm
130 cm	140 cm	80 cm	2.5 cm
150 cm	160 cm	80 cm	2.5 cm
170 cm	180 cm	80 cm	2.5 cm

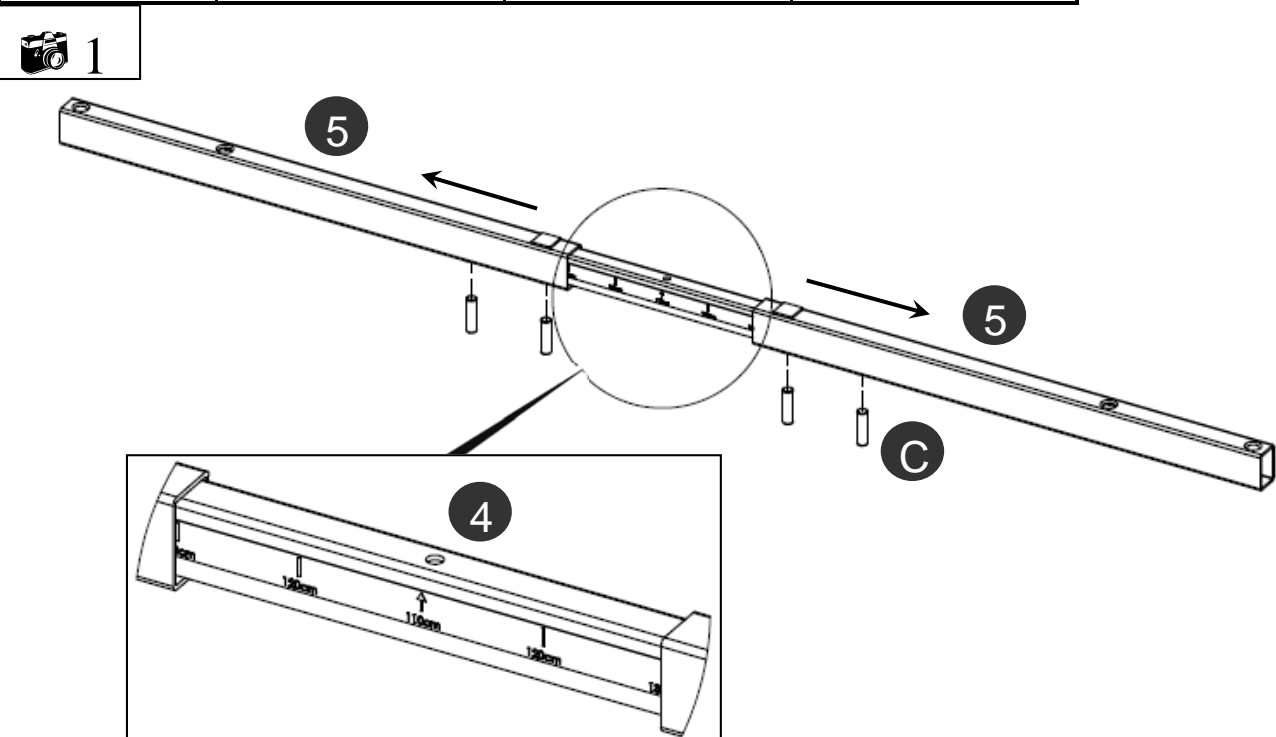

	<ul style="list-style-type: none"> • Do not yet tighten the set screws on the crossbars! • Tighten the socket screws only after assembling the components in step 3.4.5 Adjustment of the frame width, page 10.
--	---

3.4.2 Mounting the Feet

 2

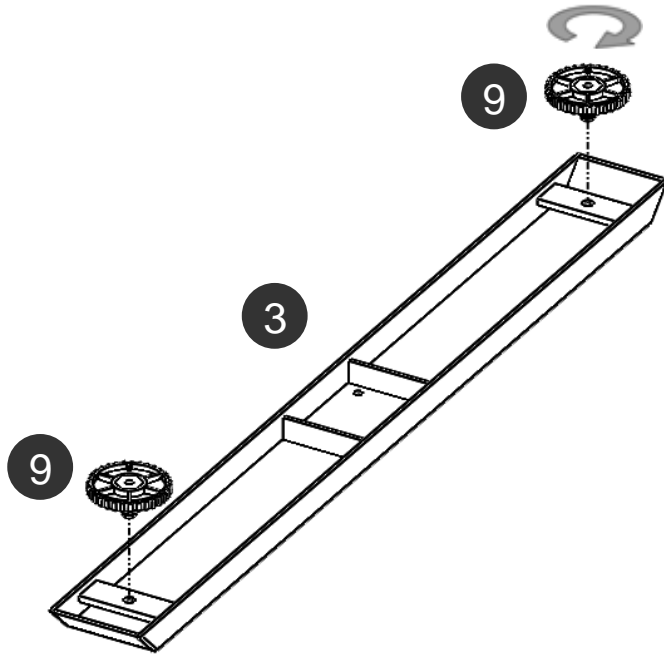

 3

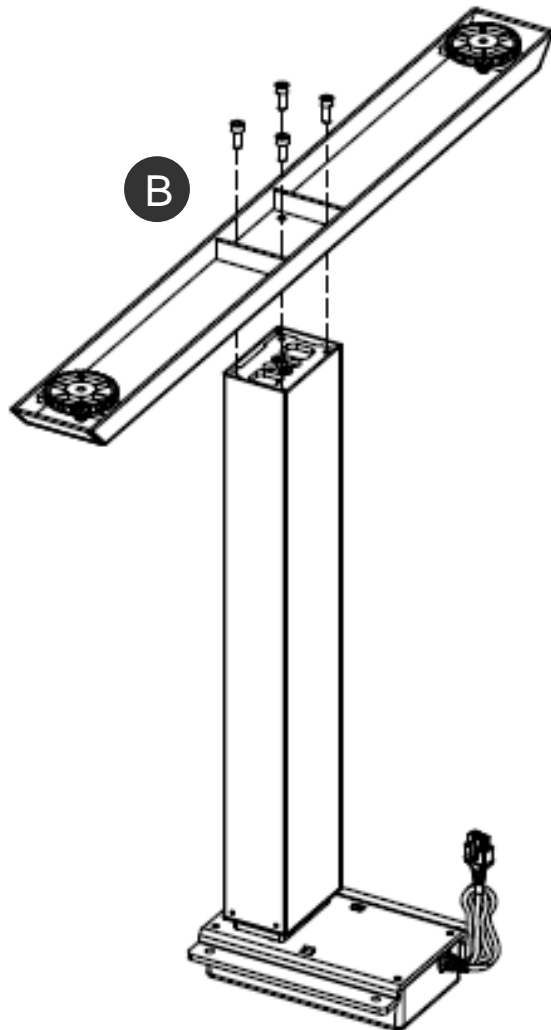

3.4.3 Mounting the Crossbar

 4

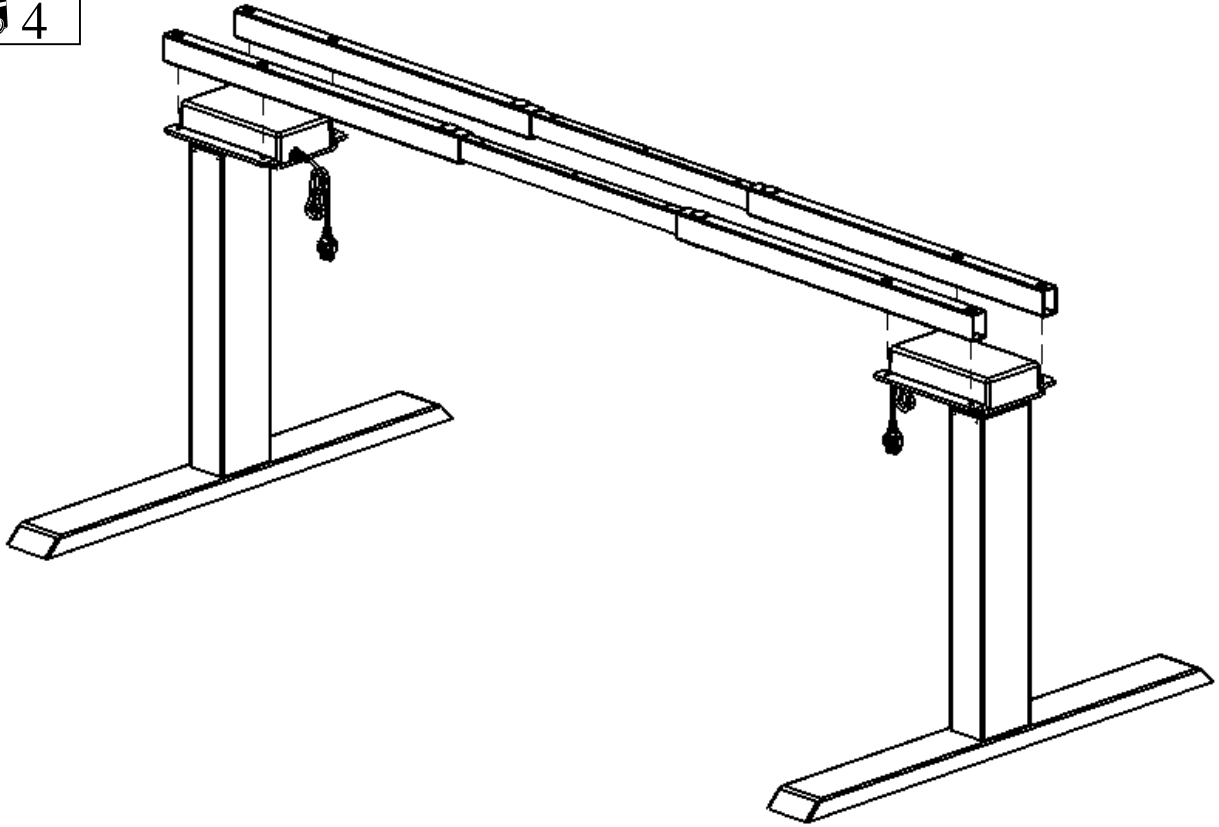

 5

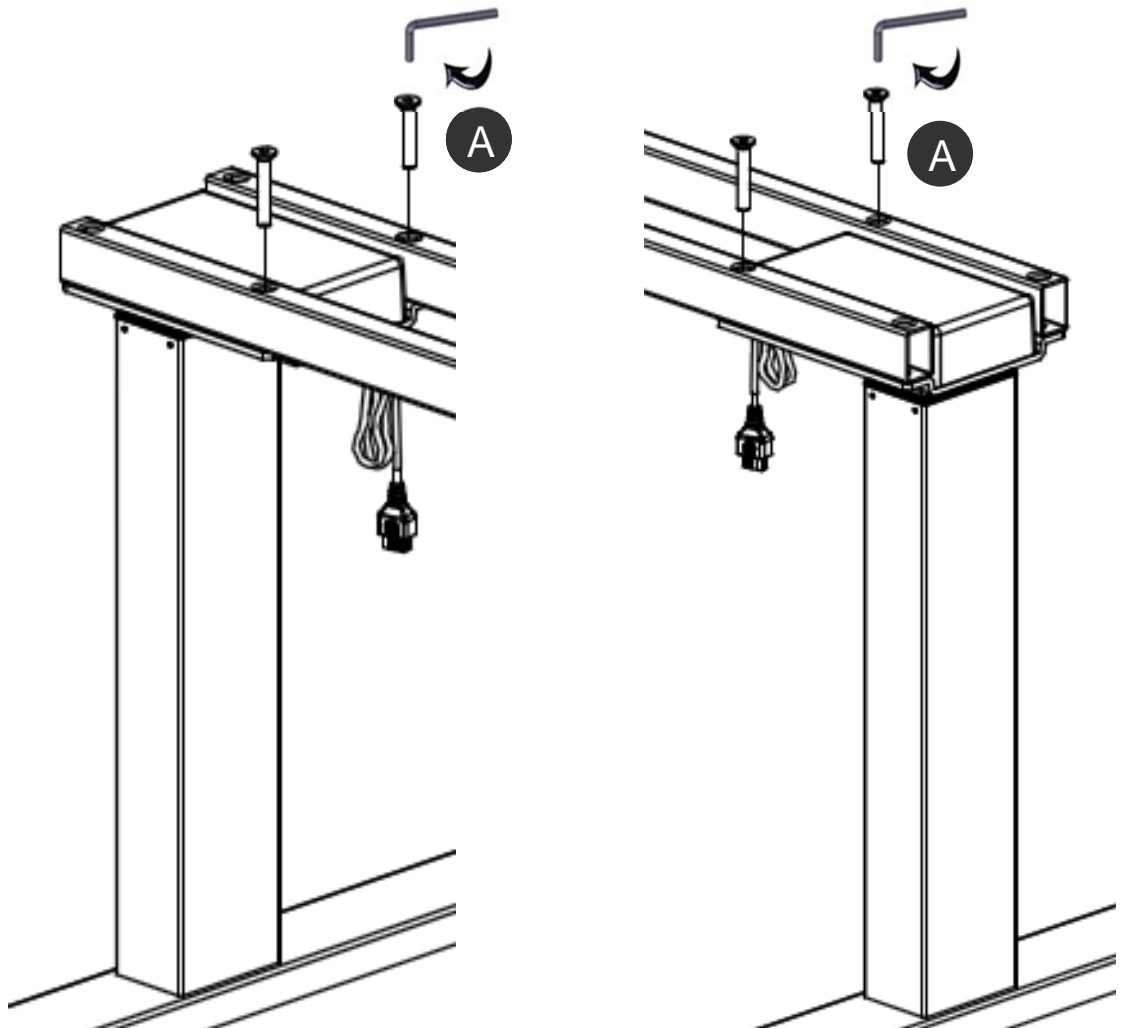

3.4.4 Mounting the Top Support

6

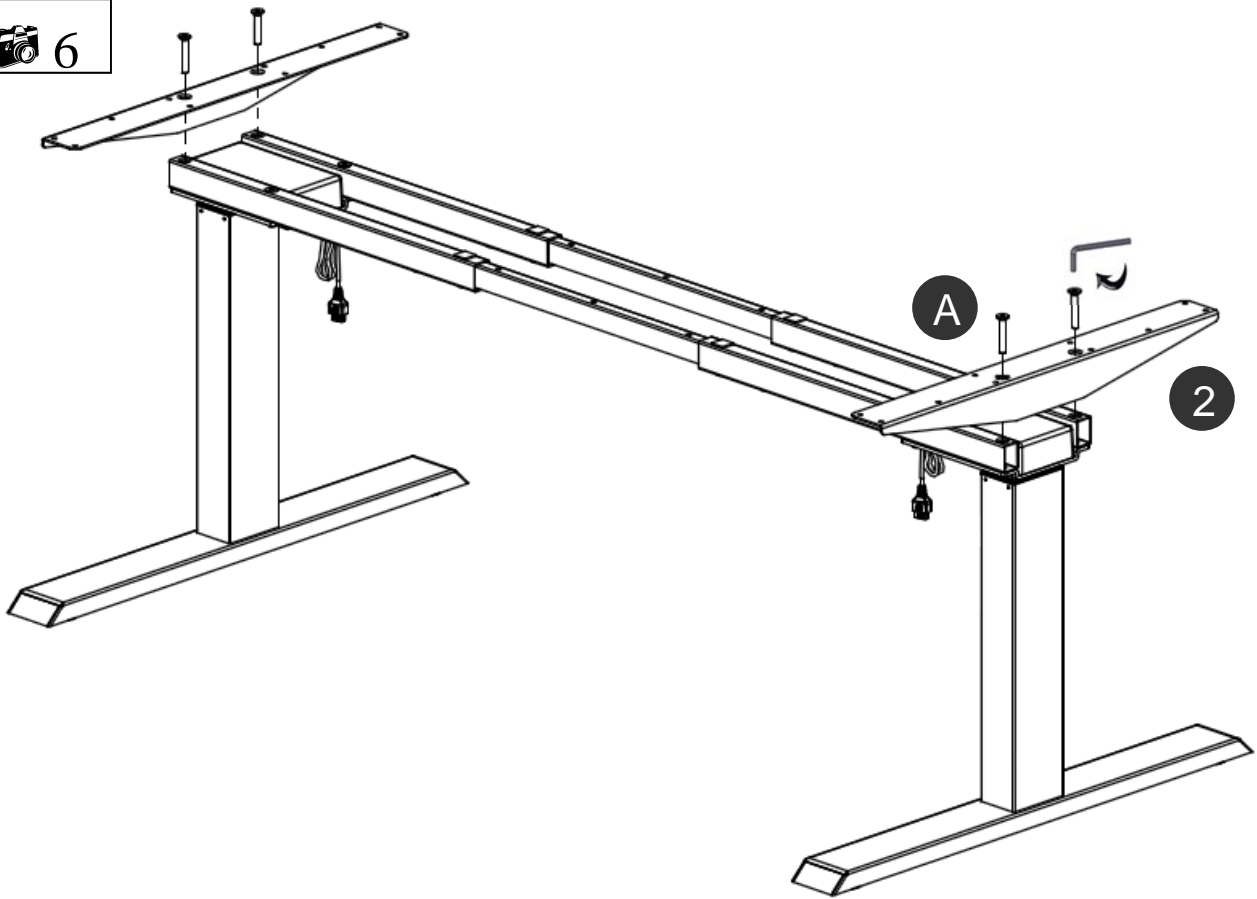

3.4.5 Adjustment of the Frame Width

7

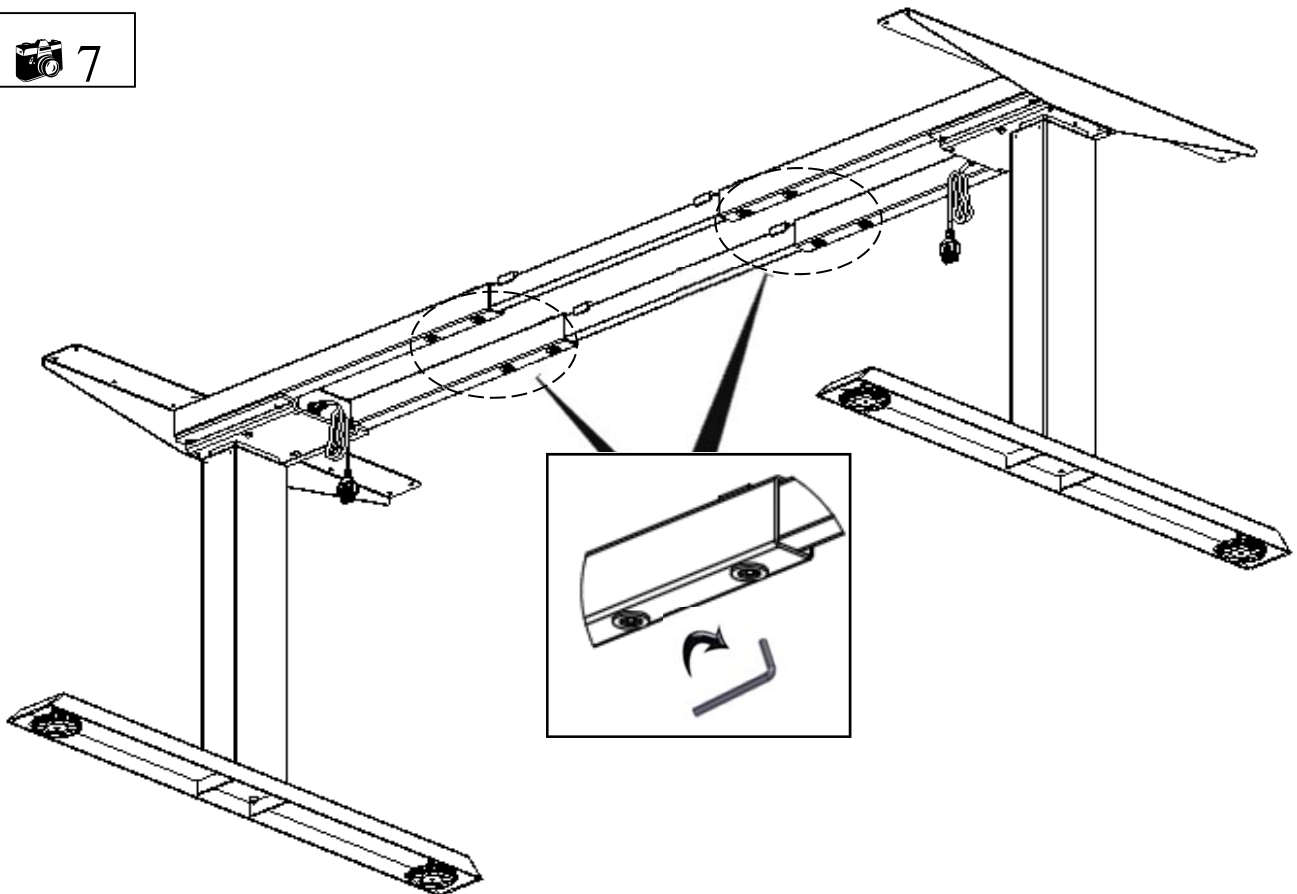

3.4.6 Mounting the Spacer

8

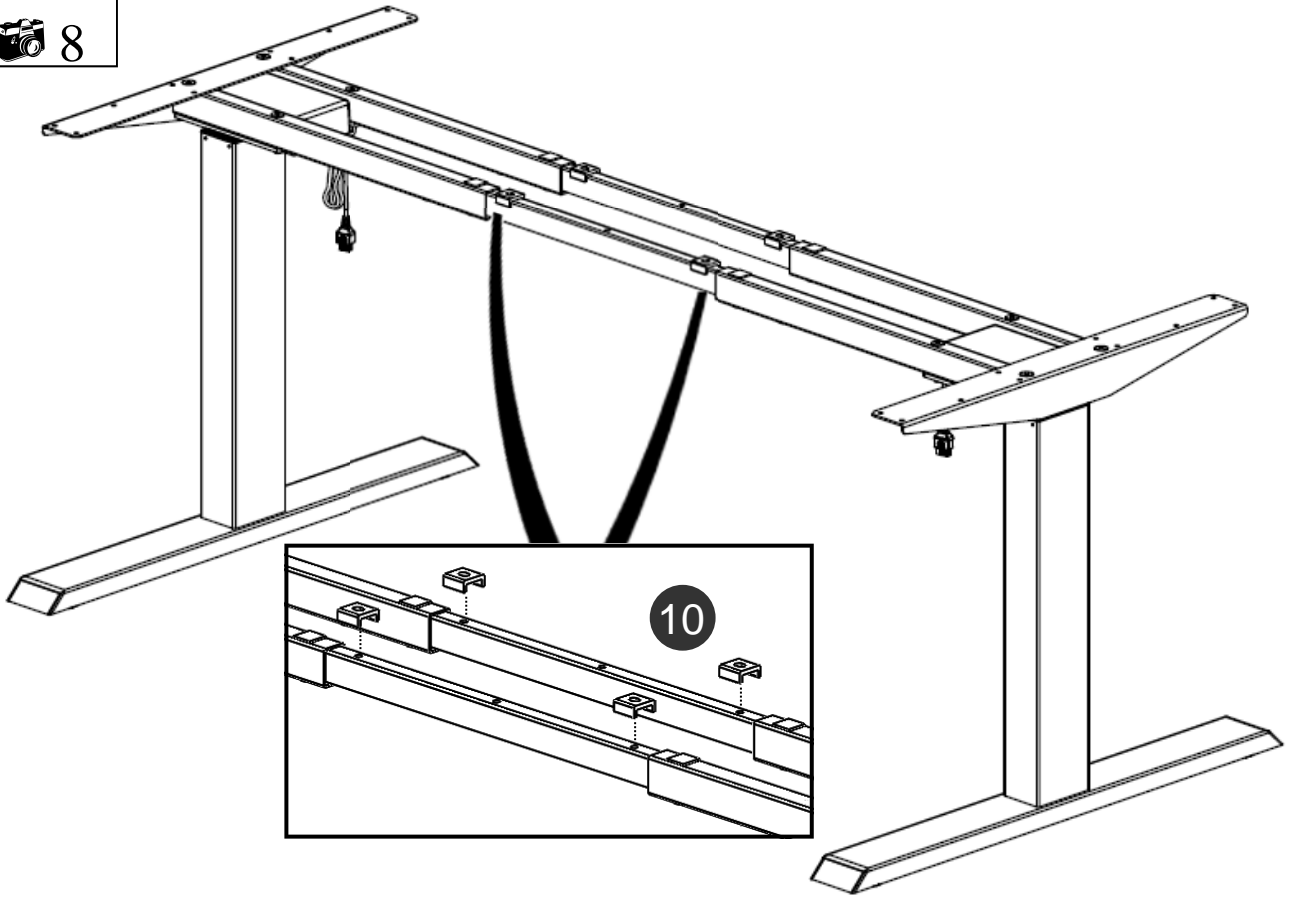

9

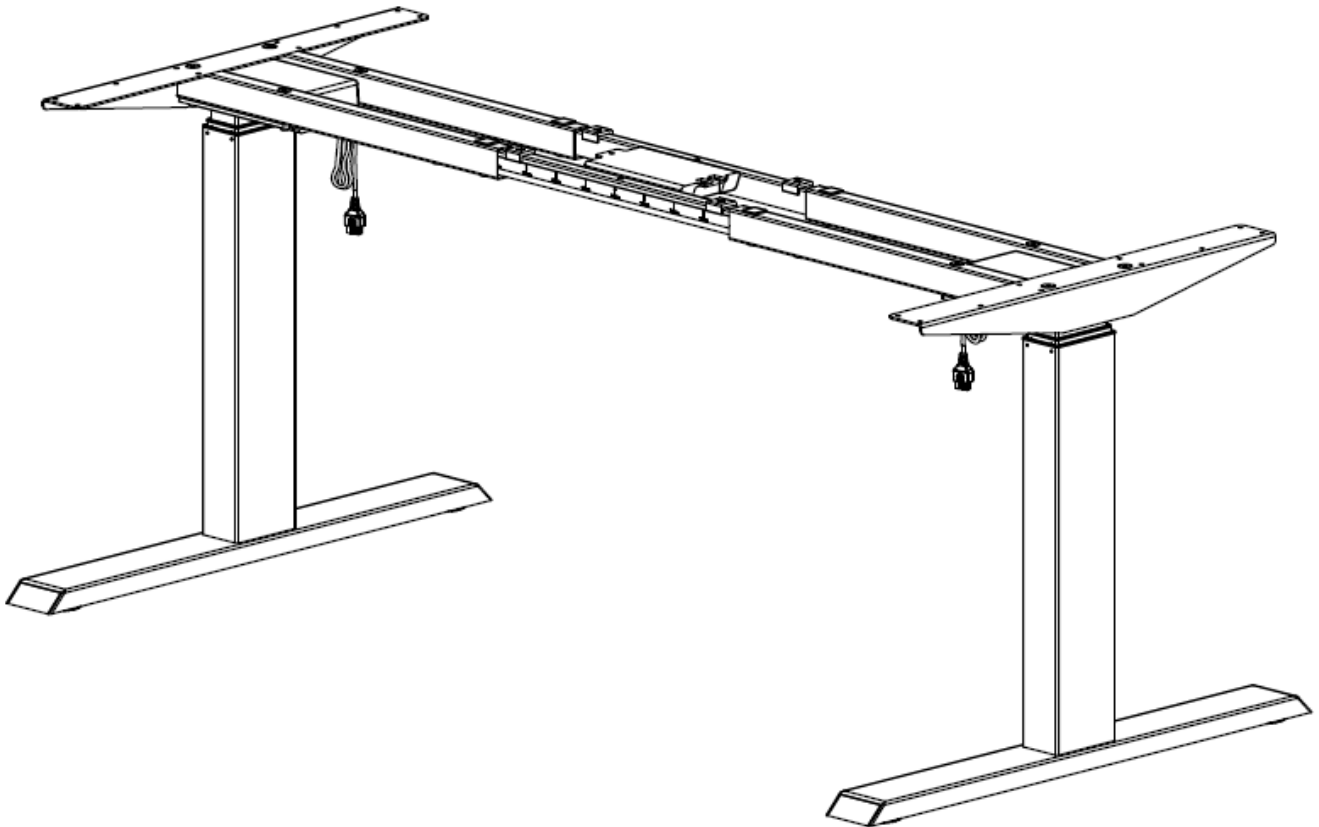

3.4.7 Connecting the electrical components

 10

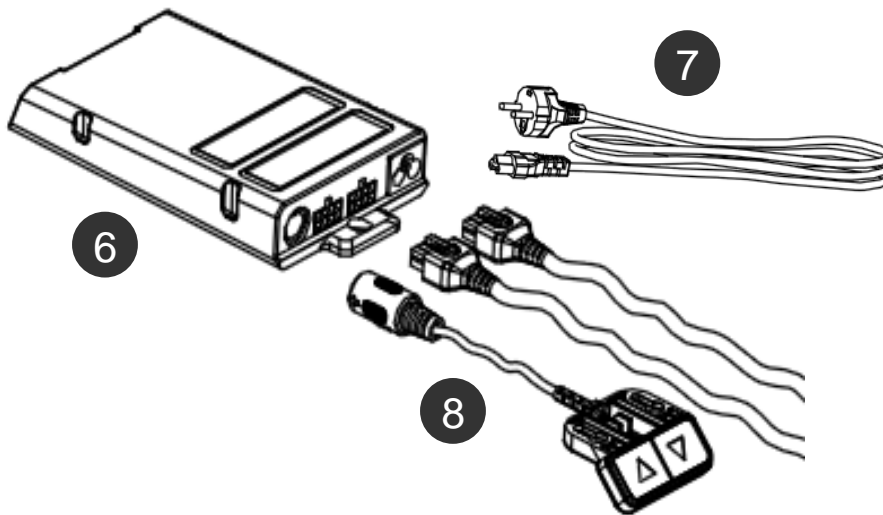

Keep in mind that the desk which you are assembling is height adjustable. The cables of the electrical components must be able to freely follow the movement of the desk.

3.4.8 Mounting the table top

3.4.9 Mounting the power supply underneath the table top

 11

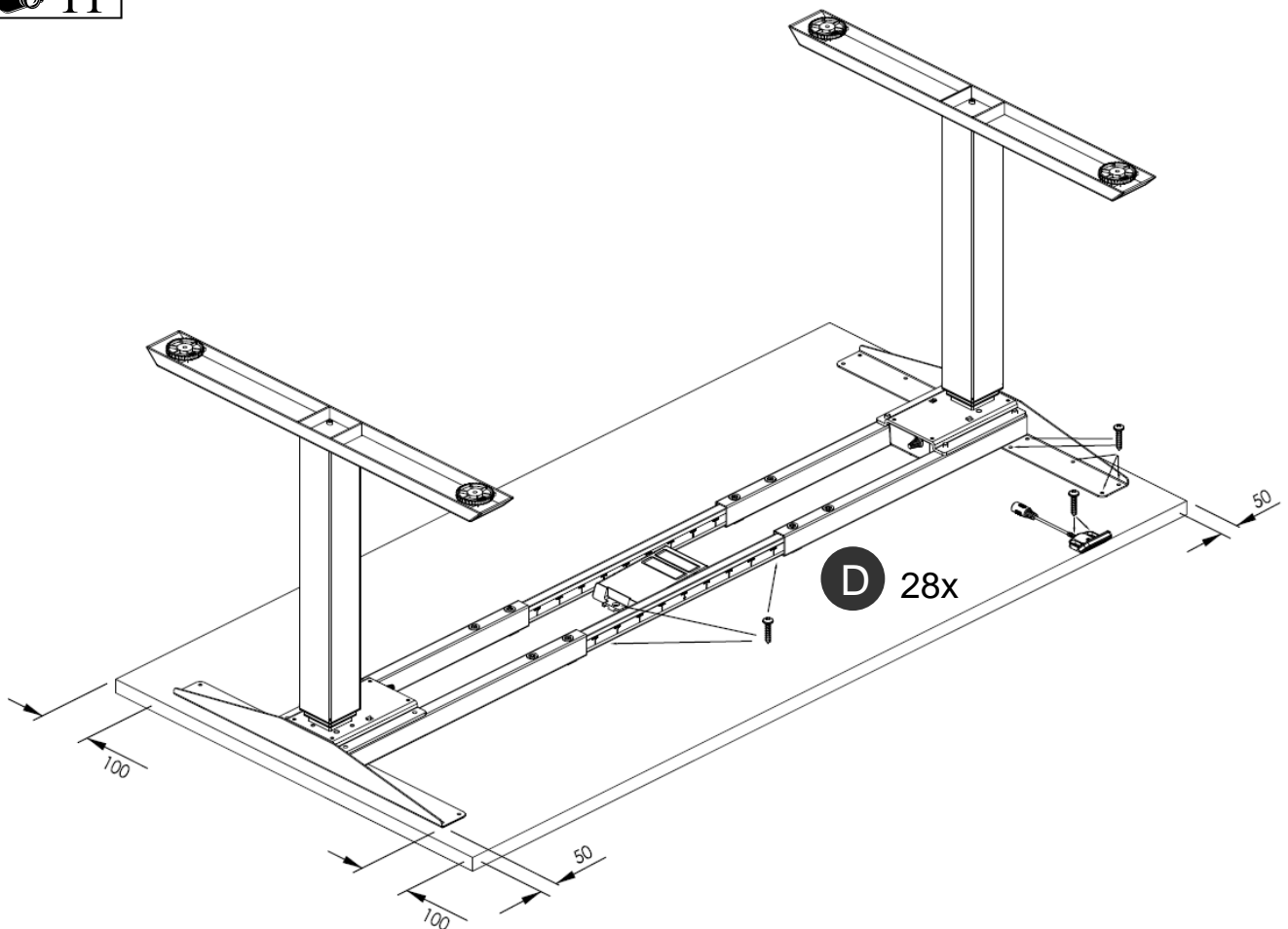

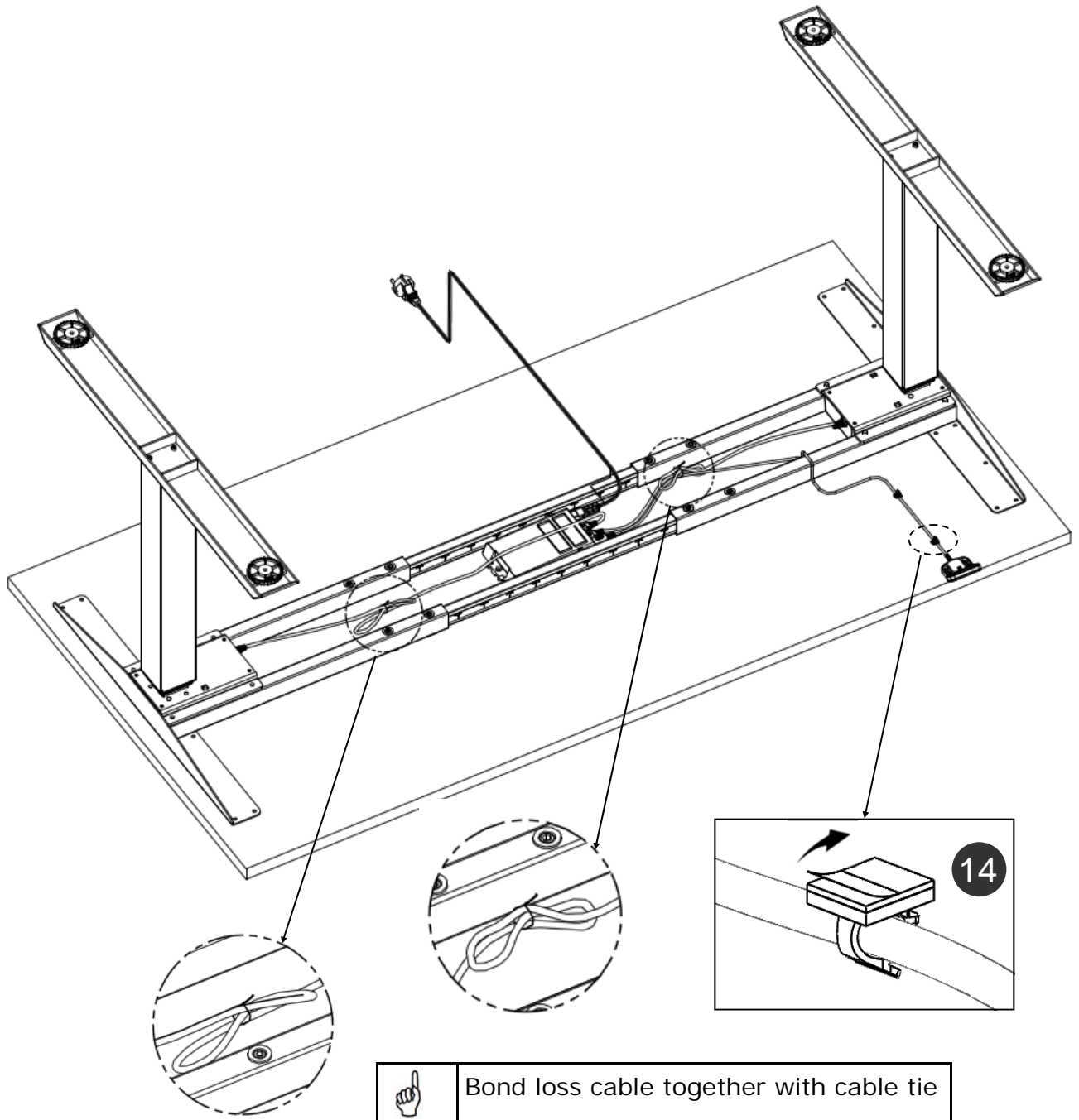

3.4.10 Mounting wire clip

 12



 Mount the wire clips for cable. Peel off paper backing and stick to table top. Place wire into each wire clip.

3.4.11 Frame test without table top

	Please make sure that the workstation frame can move freely and correct at all times.
	In case you need to disconnect cables from the electrical components always be sure to disconnect power first.
	In case the height adjustment is not operating normally, stop using the workstation frame immediately and disconnect the power. Get in contact with customer service for further advise.

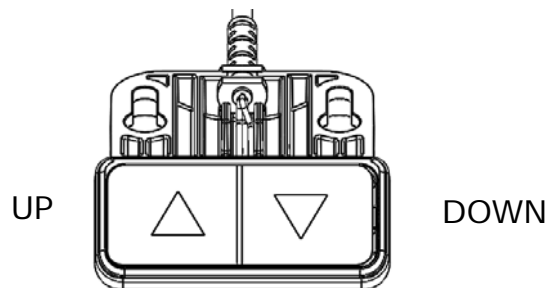

(Optional Memory Master)

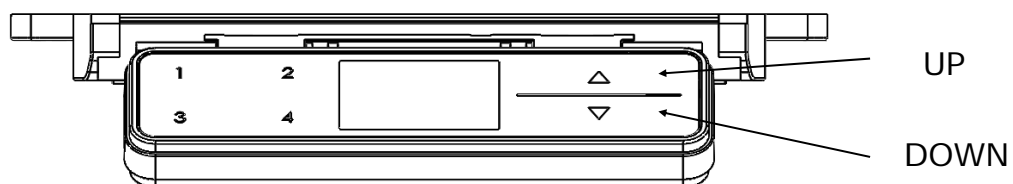

First initial mode

The first time you put in the plug of the power supply into the socket, the height adjustment can only be operated in the reset-mode. As long as the reset-mode is enabled, the system can only move downward. To end the reset-mode and use the system normally, please follow the next steps:

- Press and hold the down-button, the system slowly moves downward.
- Please move the system to the lowest position. This position will be used as reference-point (zero-point).
- Keep the button pressed for a moment when the system has reached the lowest position. This will end the reset-mode.
- The system can be operated normally now. Press and hold the up- or down-button to move the system to the desired height. The system stops when you release the buttons.

System restart—initializing the reset-mode

- Press "down-" buttons (about 10 seconds) until the sound "click" is heard.
- Proceed with the "Reset-mode" instructions listed above.

3.4.12 Clearance around the wall or moving parts 25mm of the table top

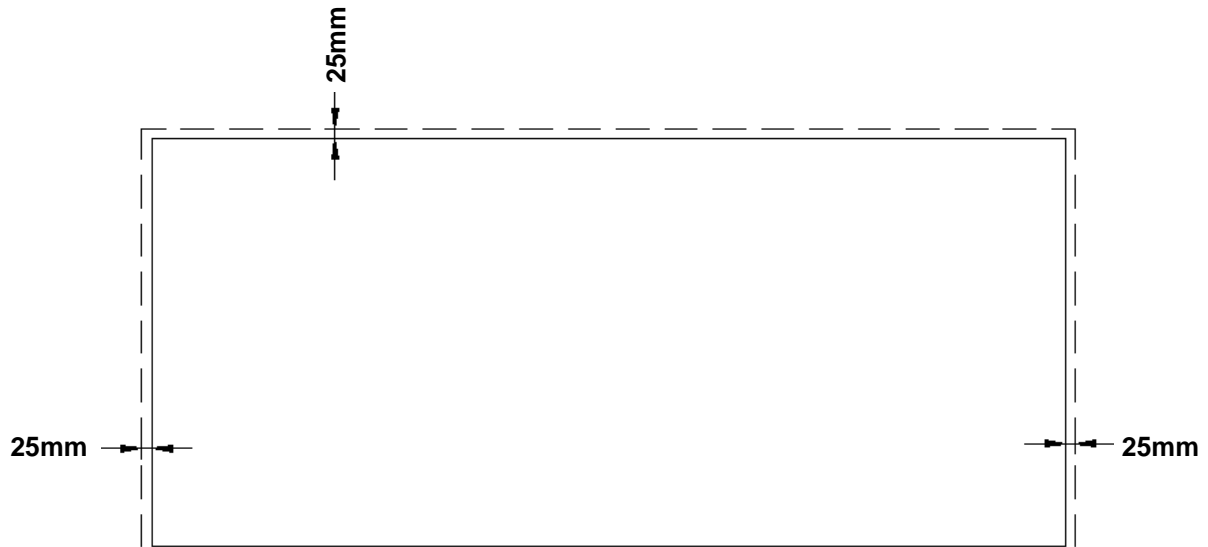

Allow a minimum clearance of 25mm from the edge of a table top to a wall or moving parts.

4 Correct position of seats

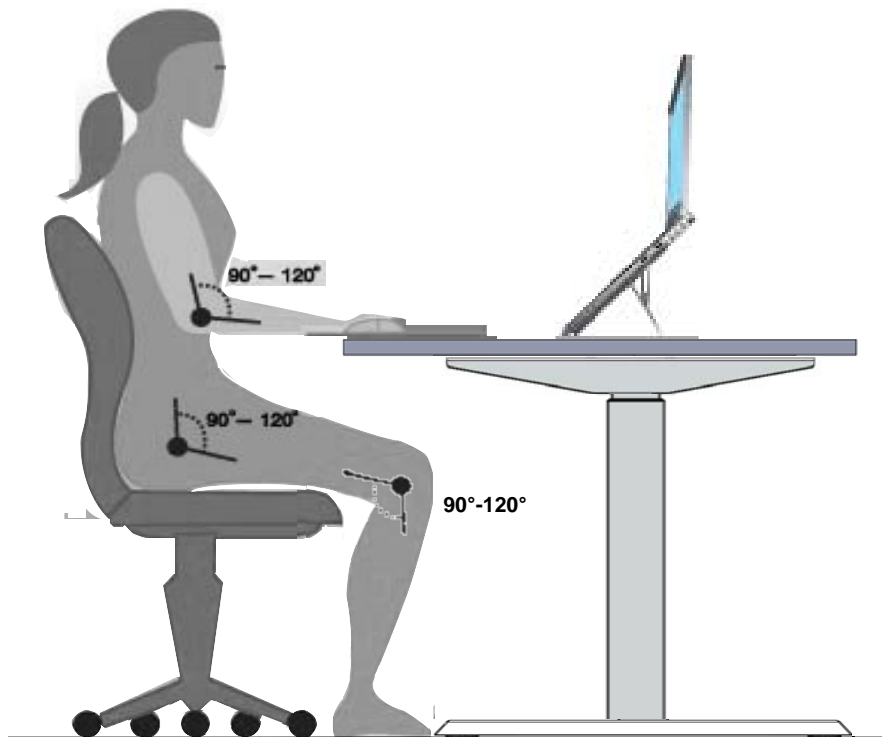

Correct sitting posture

Sitting incorrectly can lead to injuries at joints, bowstrings and muscles. In order to prevent this it is necessary to adjust your office chair and desk.

Apart from the following advice you should always prevent an uncomfortable sitting posture. If you feel that the following advice leads you to an uncomfortable sitting posture simply adapt your needs.

Office Chair

- The sitting height has to be adjusted in way that your knee is angled by 90-120° when your foot is flat on the ground.
- Sitting properly requires that your lower back touches the back rest. If possible align the seating depth in order to avoid pressure from the seat pan to your lower leg.
- Sit upright but lean back in a relaxed position. If possible adjust the lumbar support of your chair to your height.
Adjust the back rest in a way that pushes your upper body slightly forward but still offering enough flexibility to yield movement.
- If possible adjust the height of your armrests. Your shoulders should be in a relaxed position when your arms are touching the arm rest.

Desk

- Adjust the table height after you have found your correct sitting posture.
- Your elbows should be angled by 90-120° when your arms rest on the table top. The edge of the top should not press against your arms.

Equipment on the desk

- Incident light (day light or lamps) on your monitor should approach the surface of your screen by an angle of 90°.
- The height of your monitor should be adjusted in way that enables you to look slightly downward while focusing the centre of your screen.
- Please keep a distance of 60-70 cm from your screen.
- A careful posture for your wrists can be achieved by a flat narrowed keyboard.
- **Please heed the advice in the manuals of your further (ergonomical) equipment.**

5 Technical Specifications

Frame for Sit-Stand Workstation

Assembly Manual version	603003-OE
Year of release manual	2016
Production country	Malaysia
System	2-step
Material	Steel, Aluminium and Plastic
Stroke (max.)	660 mm
Frame load (max.)	80 kg
Frame weight	± 30 kg
Speed 0 kg frame load	± 46 mm/s
Speed 75 kg frame load	± 39 mm/s
Input power	220-230V/50-60Hz/2.5A
Duty cycle	10 % (2 Minute on / 18 Minutes off)
Noise level	< 55 dB(A)
Environmental temperature Use	15 - 30°C
Environmental temperature Storing	10 - 50°C
Humidity Use	<85%
Humidity Storing	<50%
Maximum Storing time	-
Indoor use only!!!	

5 Technical Specifications

(* General Tolerance = ± 1 cm)

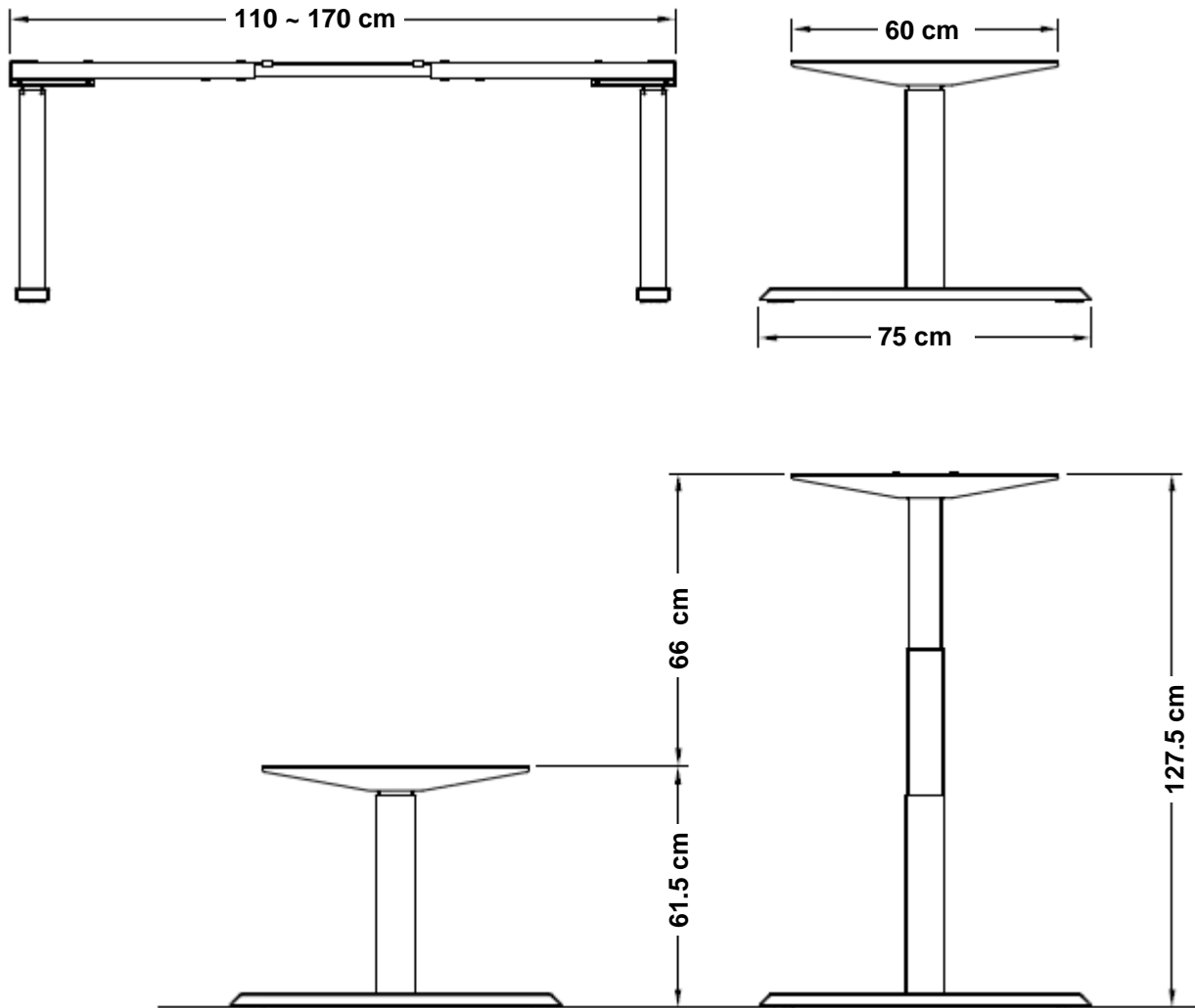

Minimum Frame Height	61.5 cm
Maximum Frame Height	127.5 cm
Maximum Stroke	66 cm
Frame Width	110-170 cm
Frame Depth	75 cm
Minimum Table Top Depth	60 cm
Maximum Frame Load	80 kg

6 Operation and Indicators

	<p>Observe the provisions of Section 2 Safety Information on page 5, in particular:</p> <p>Do not leave children unsupervised with the workstation frame. Children may be unaware of the dangers presented by the workstation frame. They would be in serious danger of injuring themselves, possibly even with fatal consequences.</p> <p>Do not exceed the maximum time lag of the workstation frame. Make sure there is ample space to avoid collisions if there are objects on the work surface such as computers or computer peripherals.</p>
---	--

6.1 Indicators

	<p>Leave the immediate surroundings of the workstation frame at once if it starts to move spontaneously. Under no circumstances attempt to operate the workstation frame. Have the workstation frame repaired by specialists. Refrain from using the workstation frame until it has been successfully repaired.</p> <p>Stop using the workstation frame at once if you notice anything unusual (strange sounds, smoke, etc.). Have the workstation frame repaired by specialists. Refrain from using the workstation frame until it has been successfully repaired.</p> <p>Stop using the workstation frame at once if its safety features fail to work as they should.</p>
---	--

7 Troubleshooting

7. Troubleshooting

Problem	Possible cause	Solution
Height adjustment does not work.	Cables or connectors defective.	Check cables for damages and if necessary replace them. Power in order?
Height adjustment does not work.	If cables and connectors have been checked a possible cause could be a defective up-down switch.	Replace up-down switch.
Height adjustment does not work.	Error in power supply.	Initialize restart.

If your problem couldn't be solved or is not listed here, please contact your customer service for further advise.

8 Customer Service

Make sure you have the workstation frame information at hand when contacting the customer service.



9 Manufacturer

Actiforce International B.V.

Xenonweg 11
3812 SZ Amersfoort
The Netherlands
+31 (0)33 4600120
www.actiforce.com
info.holland@actiforce.com

10 Recycling

10.1 Taking the workstation out of active duty

- Pull the power plug out of the electricity socket.

10.2 Taking the workstation apart

- In case of de-assembling please follow the manual backwards or contact customer service.

10.3 Recycling

- Please split all parts to their type of material. Keep notice of National restrictions!

