

Duna 02

Design by Lievore Altherr Molina, 2014

Art. 4203

Chair with oak veneer four-leg base. Polypropylene shell available in six colours.



Dimensions *

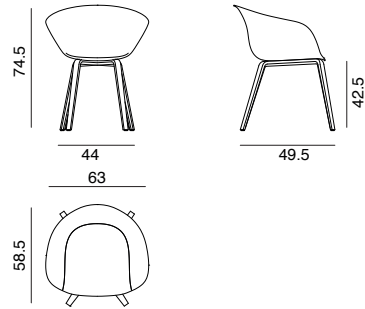

* File CAD 2D - 3D available for download at www.arper.com

Frame Base

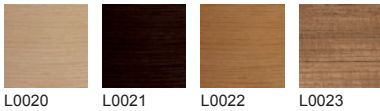

Shell

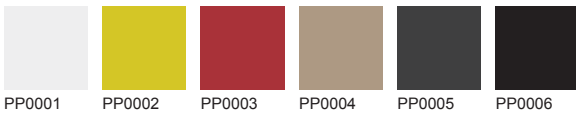

arper

www.arper.com

info@arper.com

Duna 02

Design by Lievore Altherr Molina, 2014

SHIPMENT DETAILS

Art.4203

1 pz = 2  - kg 12,88/ m³ 0,36

4 pz = 2  - kg 37,7/ m³ 0,48

RESISTANCE TEST

- EN 1728:2012 - EN 16139:2013 6.10
- EN 1728:2012 - EN 16139:2013 6.15
- EN 1728:2012 - EN 16139:2013 6.17
- EN 1728:2012 - EN 16139:2013 6.20
- EN 1728:2012 - EN 16139:2013 6.25
- EN 1728:2012 - EN 16139:2013 6.4
- EN 1728:2012 - EN 16139:2013 6.11
- EN 1728:2012 - EN 16139:2013 6.16
- EN 1728:2012 - EN 16139:2013 6.18
- EN 1728:2012 - EN 16139:2013 6.24
- EN 1728:2012 - EN 16139:2013 6.26
- EN 1728:2012 - EN 16139:2013 6.5

TECHNICAL SPECIFICATIONS

FIRE RETARDANT TEST

Classe 2 polypropylene

ENVIRONMENTAL CERTIFICATIONS



arper

www.arper.com
info@arper.com

Duna 02 Eco

Design by Lievore Altherr Molina, 2018

Art. 4241

Chair with oak veneer four-leg base. Eco-sustainable polypropylene shell with 100% recycled material obtained from post-industrial waste, available in anthracite finish.



Dimensions *

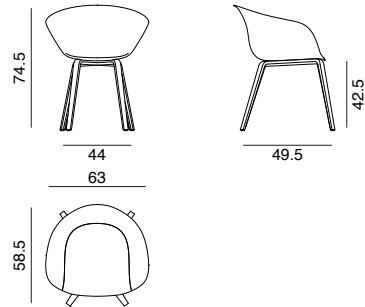

* File CAD 2D - 3D available for download at www.arper.com

Frame Base



Shell

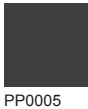

arper

www.arper.com

info@arper.com

Duna 02 Eco

Design by Lievore Altherr Molina, 2018

SHIPMENT DETAILS

Art.4241

1 pz = 2  - kg 12,88/ m³ 0,36

4 pz = 2  - kg 37,7/ m³ 0,48

TECHNICAL SPECIFICATIONS

arper

www.arper.com

info@arper.com

Duna 02

Design by Lievore Altherr Molina, 2014

Art. 4223

Chair with oak veneer four-leg base. Polypropylene shell available in six colours, with seat cushion in leather, faux leather, fabric or customer's own material.



Dimensions *

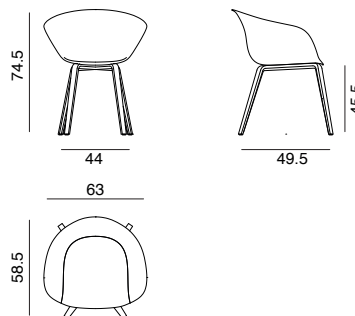

* File CAD 2D - 3D available for download at www.arper.com

Frame Base

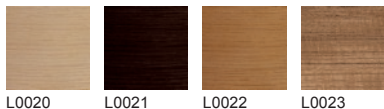

Shell



Carded In



Graded In

kvadrat

camira



DESIGN
TEX



Gabriel



svensson

maharam

Serge Ferrari

arper

info@arper.com

www.arper.com

Duna 02

Design by Lievore Altherr Molina, 2014

SHIPMENT DETAILS

Art.4223

1 pz = 2  - kg 12,88/ m³ 0,36

4 pz = 2  - kg 37,7/ m³ 0,48

RESISTANCE TEST

- EN 1728:2012 - EN 16139:2013 6.10
- EN 1728:2012 - EN 16139:2013 6.15
- EN 1728:2012 - EN 16139:2013 6.17
- EN 1728:2012 - EN 16139:2013 6.20
- EN 1728:2012 - EN 16139:2013 6.25
- EN 1728:2012 - EN 16139:2013 6. 4

- EN 1728:2012 - EN 16139:2013 6.11
- EN 1728:2012 - EN 16139:2013 6.16
- EN 1728:2012 - EN 16139:2013 6.18
- EN 1728:2012 - EN 16139:2013 6.24
- EN 1728:2012 - EN 16139:2013 6.26
- EN 1728:2012 - EN 16139:2013 6. 5

TECHNICAL SPECIFICATIONS

Art.4223

COL requirement m² 0.56

H 140 cm. COM Meterage ml 0.55

FIRE RETARDANT TEST

Classe 1M Cava 3 Field Remix 2 Steelcut 2 Steelcut Trio 2 Steelcut Trio 3 Faux leather Valencia

ENVIRONMENTAL CERTIFICATIONS



arper

www.arper.com
info@arper.com

Duna 02

Design by Lievore Altherr Molina, 2014

Art. 4213

Chair with oak veneer four-leg base and polypropylene shell available in six colours, with front upholstery in leather, faux leather, fabric or customer's own material.



Dimensions *

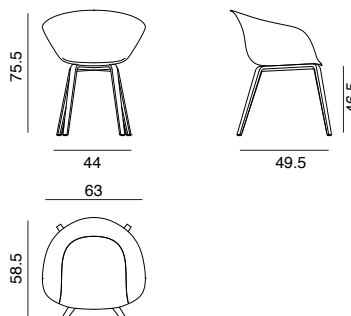

* File CAD 2D - 3D available for download at www.arper.com

Frame Base

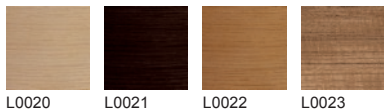

Shell



Carded In



Graded In

kvadrat

camira



DESIGN
TEX



Gabriel



svensson

maharam

Serge Ferrari

arper

info@arper.com

www.arper.com

Duna 02

Design by Lievore Altherr Molina, 2014

SHIPMENT DETAILS

Art.4213

1 pz = 2  - kg 12,88/ m³ 0,36

4 pz = 2  - kg 37,7/ m³ 0,48

RESISTANCE TEST

- EN 1728:2012 - EN 16139:2013 6.10
- EN 1728:2012 - EN 16139:2013 6.15
- EN 1728:2012 - EN 16139:2013 6.17
- EN 1728:2012 - EN 16139:2013 6.20
- EN 1728:2012 - EN 16139:2013 6.25
- EN 1728:2012 - EN 16139:2013 6. 4

- EN 1728:2012 - EN 16139:2013 6.11
- EN 1728:2012 - EN 16139:2013 6.16
- EN 1728:2012 - EN 16139:2013 6.18
- EN 1728:2012 - EN 16139:2013 6.24
- EN 1728:2012 - EN 16139:2013 6.26
- EN 1728:2012 - EN 16139:2013 6. 5

TECHNICAL SPECIFICATIONS

Art.4213

COL requirement m² 1.44

H 140 cm. COM Meterage ml 1.05

FIRE RETARDANT TEST

Classe 1M Cava 3 Field Remix 2 Steelcut Trio 2 Steelcut Trio 3 Faux leather Valencia



ENVIRONMENTAL CERTIFICATIONS

arper

www.arper.com
info@arper.com

Duna 02

Design by Lievore Altherr Molina, 2014

Art. 4233

Chair with oak veneer four-leg base. Shell fully upholstered in leather, faux leather, fabric or customer's own material.



Dimensions *

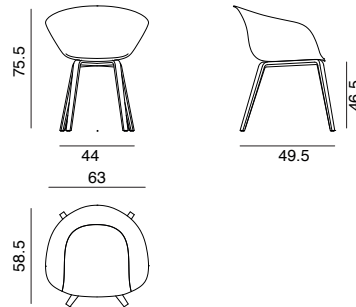

* File CAD 2D - 3D available for download at www.arper.com

Frame Base



Shell

Carded In



Graded In

kvadrat

camira



DESIGN
TEX



Gabriel



svensson

maharam

Serge Ferrari

Duna 02

Design by Lievore Altherr Molina, 2014

SHIPMENT DETAILS

Art.4233

1 pz = 2  - kg 12,88/ m³ 0,36

4 pz = 2  - kg 37,7/ m³ 0,48

TECHNICAL SPECIFICATIONS

Art.4233

COL requirement m² 2.66

H 140 cm. COM Meterage ml 1.72

RESISTANCE TEST

- EN 1728:2012 - EN 16139:2013 6.10
- EN 1728:2012 - EN 16139:2013 6.15
- EN 1728:2012 - EN 16139:2013 6.17
- EN 1728:2012 - EN 16139:2013 6.20
- EN 1728:2012 - EN 16139:2013 6.25
- EN 1728:2012 - EN 16139:2013 6. 4

- EN 1728:2012 - EN 16139:2013 6.11
- EN 1728:2012 - EN 16139:2013 6.16
- EN 1728:2012 - EN 16139:2013 6.18
- EN 1728:2012 - EN 16139:2013 6.24
- EN 1728:2012 - EN 16139:2013 6.26
- EN 1728:2012 - EN 16139:2013 6. 5

FIRE RETARDANT TEST

ENVIRONMENTAL CERTIFICATIONS



arper

www.arper.com
info@arper.com